



Ploughs

Eurostar • Titan • Taurus



REGENT – A STRONG BRAND



Plough technology by Regent

For more than 90 years Regent has been developing, producing and distributing innovative technology for soil cultivation and seeding technology rooted in its home site in Attnang-Puchheim. Our targets: increase the productivity of our customers, reduce operating costs and steady improve the profitability of our machines.

Our motivation is cross-generational passion – a must is transparency and an easy adjustment of our machines. Closely connected with farmers of today and tomorrow we are always focused on the customer.

Your advantages:

- more than 90 years of experience in plough technology
- easy and comfortable use
- robust construction for a long service life
- effective and powerful
- easy moving and fuel-efficient



The plough – the symbol of agriculture

Conventional sowing methods with the use of a plough were and are still effective, the use of plough technology involves many advantages for soil cultivation.

Your advantages in the overview:

- effective weed control through withdrawal of light
- effective pest control through withdrawal of UV-light
- Effective control of weed growing from the edge into the field (especial for small field structures)
- quick heating of the soil through improved soil aeration and air pockets
- prevention of the risk of infection (Fusaria moulds) of subsequent crop by elimination of previous crop residues
- control of mice, snails and the like by interrupting the ground cover
- accelerated reaction activity through oxygenation of the soil



Eurostar / Titan / Taurus

EFFECTIVE, ROBUST, THOUGHTFUL

The model ranges Eurostar, Titan and Taurus are made of high quality steel. The combination of quality steel and know-how of more than 90 years enables perfect technology for a small to a large enterprise.

Eurostar

- Tractors from 60 to 400 HP
- Cutting widths from 28 to 53 cm adjustable mechanically
- Frame dimensions from 100 to 180 mm
- Frame thickness up to 10 mm
- Furrows available from 2 to 6

Titan

- Tractors from 90 to 450 HP
- Cutting widths from 29 to 60 cm adjustable hydraulically
- Frame dimensions from 100 to 200 mm
- Frame thickness up to 12 mm
- Furrows available from 3 to 6

ONLY WITH THE RIGHT TECHNOLOGY YOU ARE PREPARED FOR EVERYTHING

Taurus E

- Tractors from 170 to 380 HP
- Cutting widths from 37 to 52 cm, selectable mechanically
- Frame dimensions 180 mm
- Frame thickness up to 10 mm
- Furrows available from 6 to 8

Taurus

- Tractors from 170 to 500 HP
- Cutting widths from 33 to 55 cm, adjustable hydraulically
- Frame dimensions from 180 to 200 mm
- Frame thickness up to 12 mm
- Furrows available from 6 to 9



Two strong elements of each reversible plough

The mounting tower – Core of the functions

Different sizes of the mounting tower enable different performances. Depending on the plough model the mounting tower which suits to the power class is mounted and combined with the frame. Through the headstock construction the power transmission of the bolt to the mounting tower is strengthened. The wide bearing technology is made of two big dimensioned taper roller bearings which ensure highest stability and a long service life.

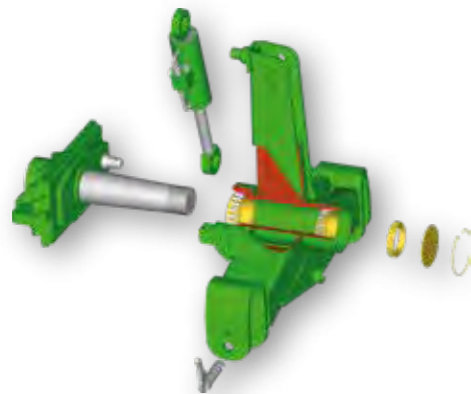

The frame – Central pillar of the plough

The second core piece of every reversible plough. Depending on the plough model different body distances are available. For every use, if it is for grassland or broad ploughing in autumn with crop residues it is easy to choose the right body distance. Through the unique segment frame construction it is possible to extend ploughs with an additional share. Big dimensioned and slanted installed flange plates enable highest stability. That is why the power from the headstock can be guided up to the last share.



Headstock with swivel axis

Upon request reversible ploughs can be equipped with a swivel axis. Obstacles are no problem on the field – you can easily plough a curve. Of course the plough can be put in an inclined position with the swivel axis for the transport on the street, so the transport width can be reduced.



Frame support plates

To increase the performance the stability of the frame can be increased through frame support plates. So an additional connection between main bearing bolt and frame can be built, through this extended space of the bearing there can be transferred even more power by the main bearing bolt. The pulling forces and the frame load in the area of the first share can also be reduced hereby.

Available for Eurostar 400-700 and Titan 140-200



ON-land

Through the proved on-land headstock technology you can drive outside the furrow, so bigger and broader wheels or track roller units can develop their power and therefore counteract soil compaction. (only for Taurus and Titan 200-4)



Leg form and guiding

The special developed sickle leg made of high-alloyed Q & T steel enables spacious free space for all plough models. That is why the earth flow with all crop residues can be led without blockages. Milled screw faces enable an exact connection between frame and share.



Overload protection

All plough models are equipped with an overload protection with shear bolt as standard. The non-stop models offer in addition a mechanical overload protection as standard, optionally these models can be equipped with a hydraulic overload protection.

CX Adjustment centre – the perfect solution packed perfectly

The CX adjustment centre is characterized by its brilliant transparency. At a glance all possibilities of adjustment are shown. The cutting width of the first body is adjusted through the spindle **C**, which is placed across to the driving direction. With the spindle **X** the pull point for ploughing without side draught is adjusted. The indicating scale enables immediate detection, if the pressure of the system increases or decreases. The angle of inclination (**N**) of the plough is adjusted independently with two spindles on the left and right of the mounting tower.

Your advantages:

- Simple, clear, self-explanatory
- close-to-center construction of the plough due to its compact design
- stepless and easy adjustment of the cutting width of the first body
- no change of the pull point due to a parallel shift

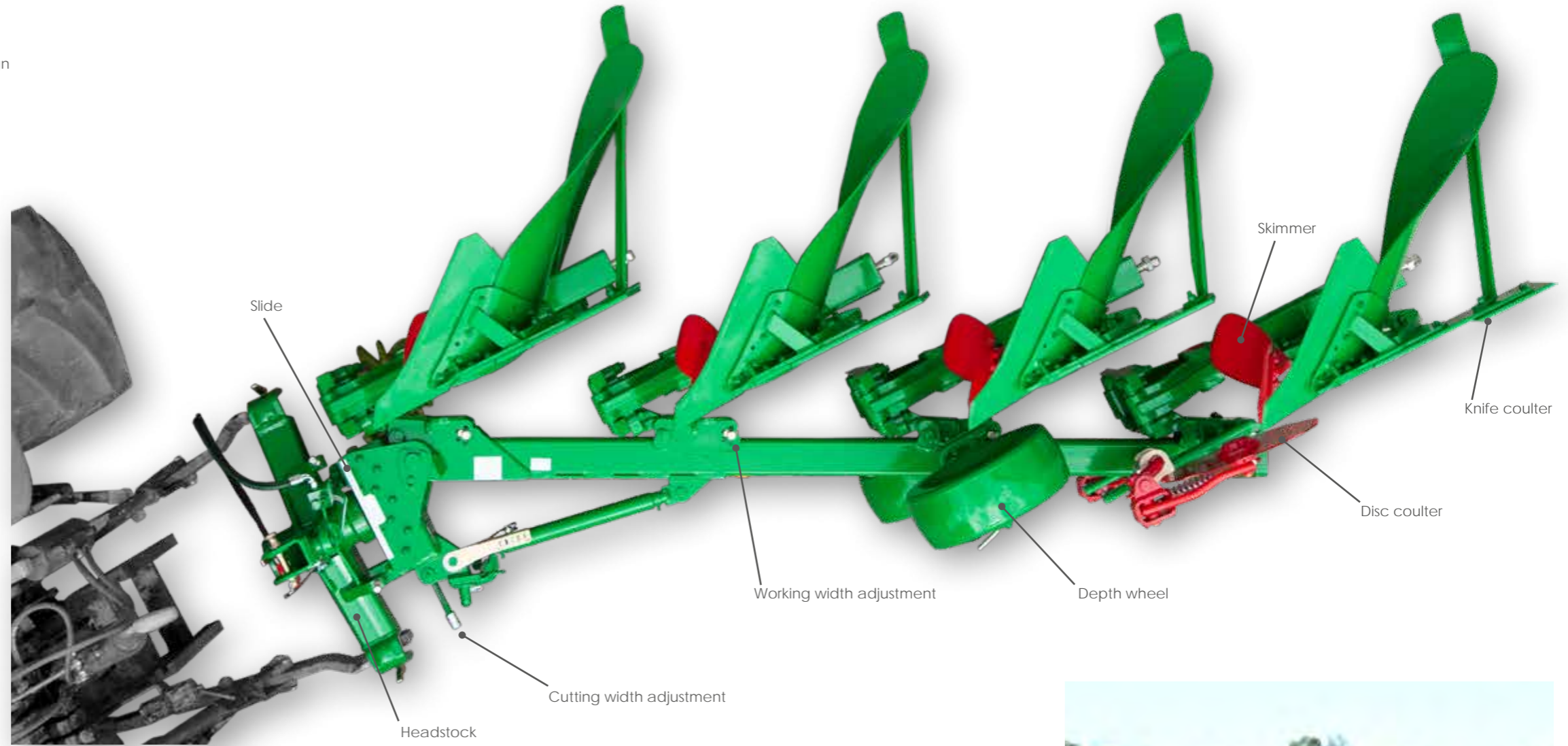
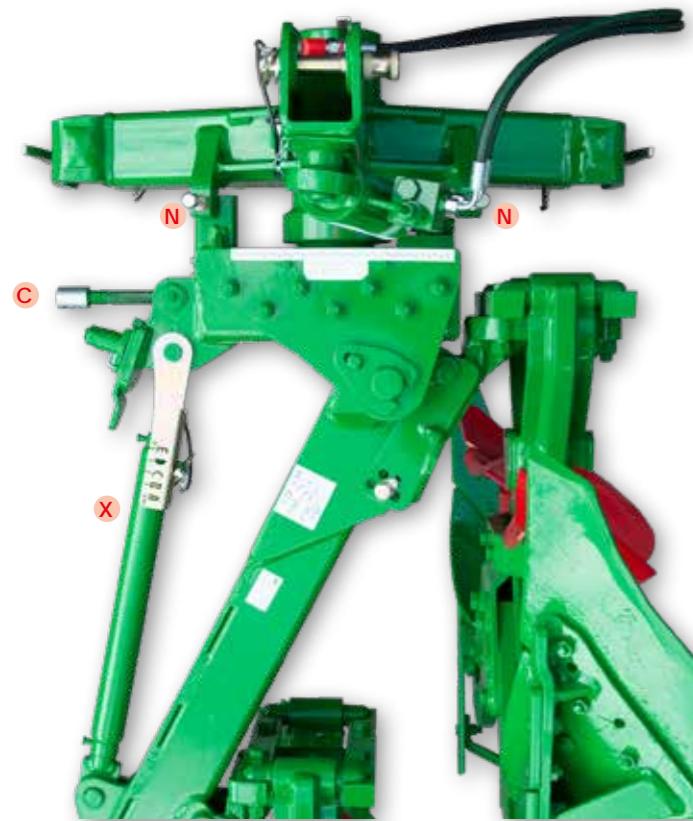

Bearing technology

The bearing technology of the model series Eurostar is characterized by its high stability. This is achieved by a maximum of one bore in the frame per body pair plus an additional reinforcing plate in the area of the bore.

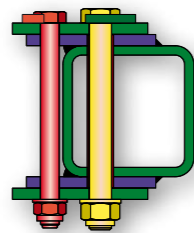

Working width adjustment

All Eurostar models have a mechanical working width adjustment as standard. With 4-6 steps, depending on the model, the cutting width can be adjusted easily and quickly. So the plough can be adapted perfectly to the respective conditions.

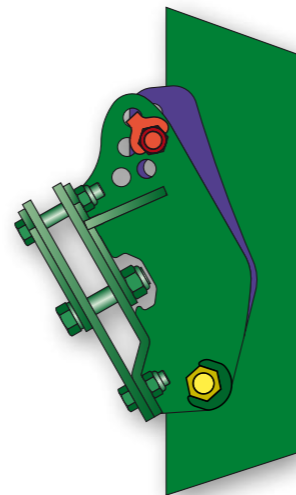

Alignment cylinder

The alignment cylinder enables turning of bigger ploughs of the model series Eurostar. This plough swivels in the main frame during the turning process, so a high ground clearance is granted. (recommended as of 5 shares)



Titan

Modern technology for highest performance

CX Adjustment centre – the perfect solution packed perfectly

The CX adjustment centre is characterized by its brilliant transparency. At a glance all possibilities of adjustment are shown. The cutting width of the first body is adjusted through the spindle **C**, which is placed across to the driving direction. With the spindle **X** the pull point for ploughing without side draught is adjusted. The indicating scale enables immediate detection, if the pressure of the system increases or decreases. The angle of inclination (**N**) of the plough is adjusted independently with two spindles on the left and right of the mounting tower.

Your advantages:

- Simple, clear, self-explanatory
- close-to-center construction of the plough due to its compact design
- stepless and easy adjustment of the cutting width of the first body
- no change of the pull point due to a parallel shift

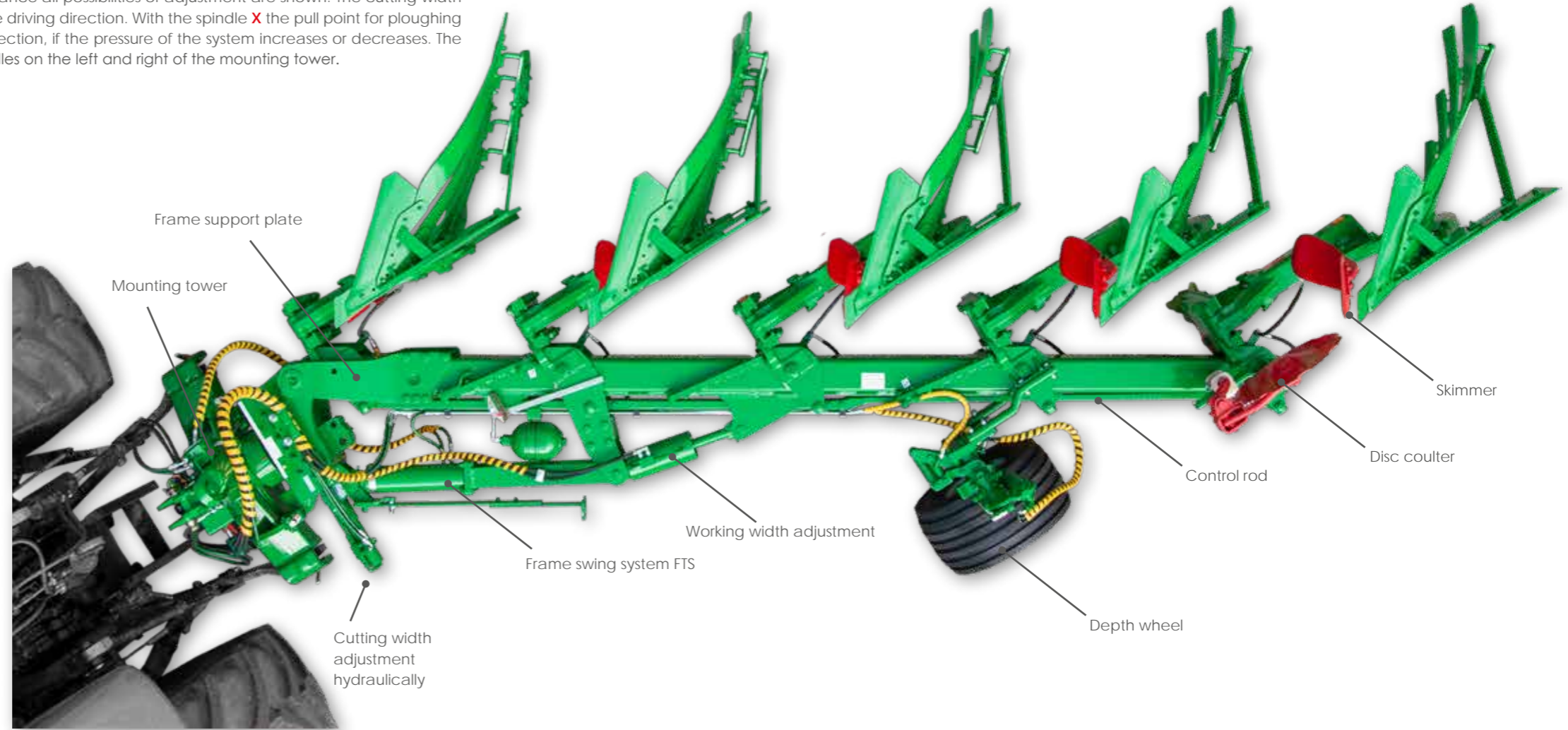
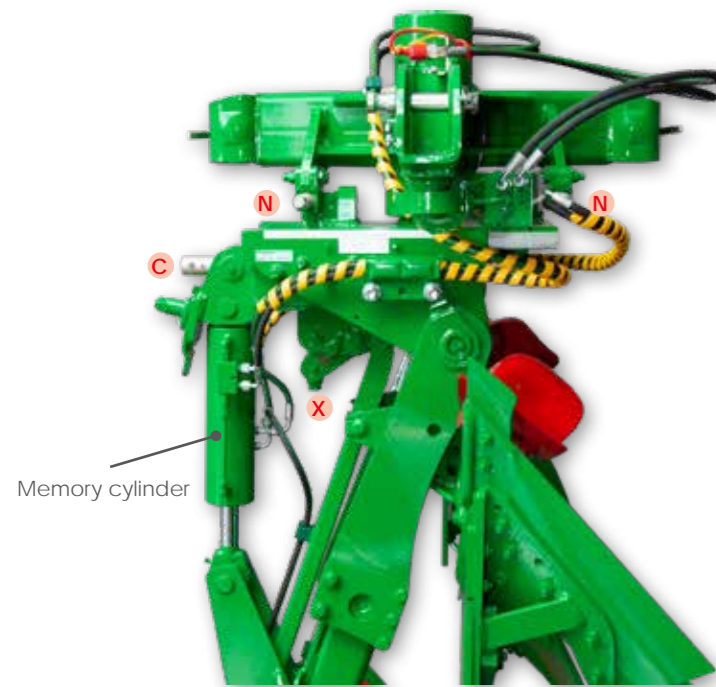

Bearing technology

The model series Titan includes two different types of bearings. Depending on the respective type of model it has a lubrication or lubrication-free bearing technology. A maximum of one bore in the frame per body pair enable highest stability and constant readiness.

Bearing technology with lubrication

Classical and proved

Your advantages:

- Continuous bush for additional stability
- Integrated lubrication channel
- Integrated grease chamber

- ① bearing bolt with lubrication
- ② Continuous bush with lubrication channel
- ③ Grease chamber
- ④ Frame profile
- ⑤ Additional frame reinforcement depending on the type of model inside or outside welded

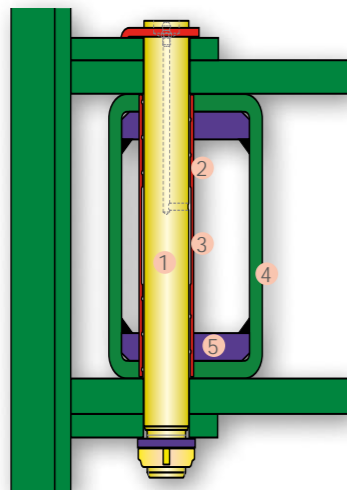

Lubrication-free bearing technology

The new generation of bearing technology

Your advantages:

- No maintenance costs
- Reducing of laytime
- High-alloyed bolts made of Q & T steel
- Absolutely maintenance-free and resistant to corrosion

- ① Lubrication-free bearing bolt made of high-alloyed Q & T steel
- ② Frame profile
- ③ Additional frame reinforcement depending on the type of model inside or outside welded

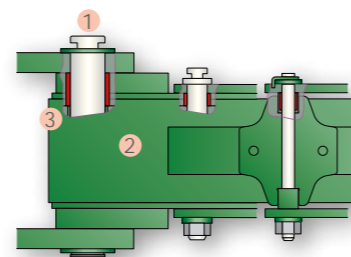

ONLY WITH EXPERIENCE YOU CAN DO GREAT THINGS

Frame swing system FTS

The frame swing system FTS swings the frame of the plough to the centre of the tractor before the turning process without changing the adjusted cutting width. Hereby the lifetime of the bearing of the plough body is maximised and above all an overlapping of the priority axis with the rotary axis is achieved. The outcome is a turning process with strongly reduced loads for the headstock of the plough and for the tractor hitch.

Your advantages:

- Small width for street transport
- Frame swivelling without crossing the cutting width
- Overlapping of priority axis and rotary axis
- Increased security at turning (especial for hillsides)
- Decreased peak loads at the headstock
- Decreased peak loads at the tractor hitch
- Increased stability for a long lifetime

Working width adjustment

All Titan models have hydraulic working width adjustment as standard. Through a double-acting hydraulic cylinder the cutting width can easily and comfortable be adjusted from the tractor. This allows an easy ploughing out of wedge-shaped surfaces.

Memory cylinder

When ploughing without FTS system we recommend the use of a memory cylinder. Beside the hydraulic working width adjustment this cylinder includes one further function: During the turning process the plough is adjusted to the smallest working width. After the turning process the memory cylinder adjusts again to the working width before the turning process had started. So there is achieved more ground clearance during the turning process and the loads for the headstock of the plough and the tractor hitch can be reduced.

Taurus E / Taurus

Strong technology for high performance of area

Connecting the proven technology of reversible ploughs (Eurostar, Titan) and the semi-mounted chassis.

Through this combination the easy CX adjustment technology is preserved also for the Taurus semi-mounted reversible ploughs.

The mounting tower

The stable mounting tower has got lower lifting arms which can transfer the high power to the plough. A big dimensioned universal joint makes a perfect adaption possible. Through two big dimensioned hydraulic cylinders a force-locking and totally impact-free turning of the plough is achieved. The universal joint and the transport wheel are placed far in the front so that a small turning radius on the headland is given. Manoeuvring a plough for big areas has never been so simple.



The working width adjustment

The model Taurus E has a mechanic working width adjustment as standard. Through 5 steps the cutting width can be adjusted easily.

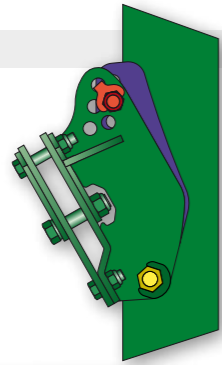

The model Taurus has a hydraulic working width adjustment as standard. Through a double-acting hydraulic cylinder the working width can be adjusted easily and comfortable from the tractor.



On-land version

At the on-land version the plough is placed for ploughing outside the furrow by a swing arm. There is a better centre of gravity position for the transport on the street by swivelling the swing arm.

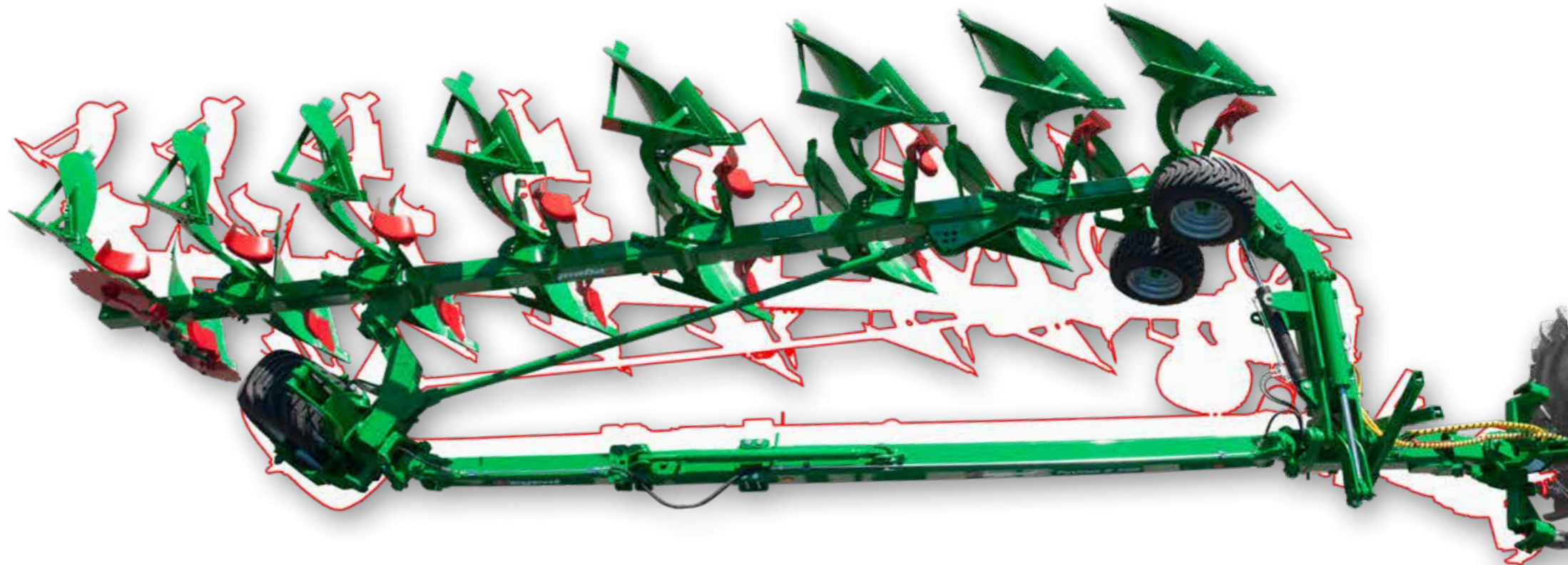

NON-STOP OVERLOAD PROTECTION

Ploughing also on stony soils

The plough models non-stop offer in addition to the already existing shear bolts a mechanic overload protection as standard. As option you can choose a hydraulic overload protection.

Your advantages:

- No lateral load of the legs
- High lifetime through pressure unit inside
- Additional security through shear bolts
- Automatic dodging of mounted discs and tillage tools
- Non-stop ploughing without a break



4-point mounting

Through a broad 4-point mounting of the non-stop elements a shock-free release, a high power transmission and dodging in all directions is possible. An independent and strong move-in of the plough body into the soil is also a part of this system.

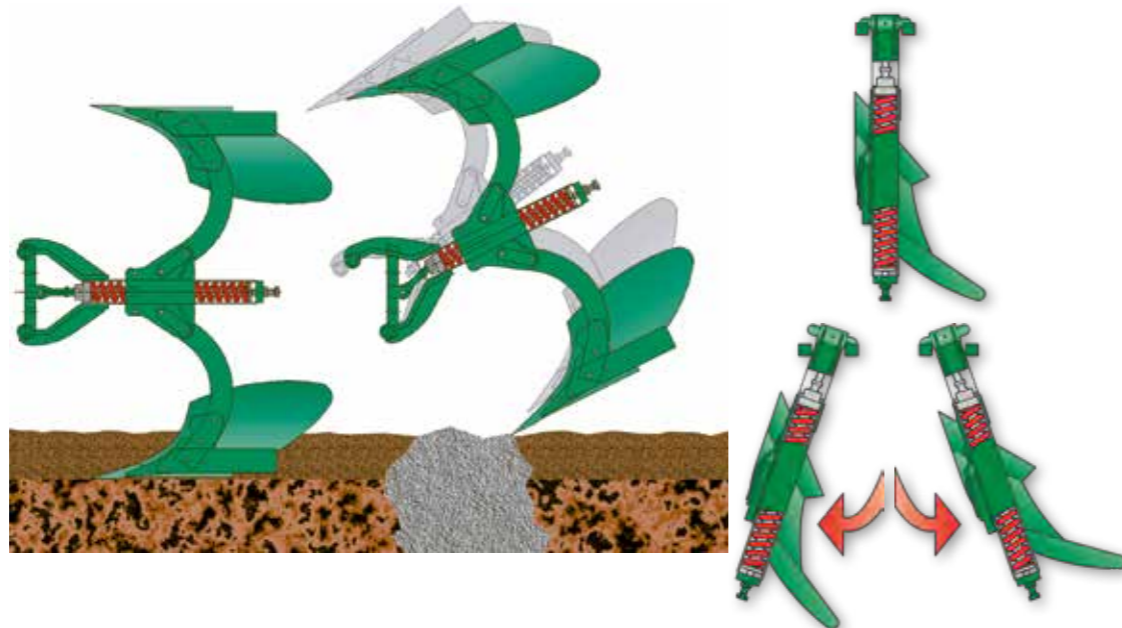

ONLY WITH THE RIGHT DETAIL YOU CAN DO GREAT THINGS



Mechanic non-stop overload protection

The mechanic non-stop overload protection has an inside mounted pressure spring. Through an outside placed adjusting screw the triggering pressure can be changed easily and comfortable.

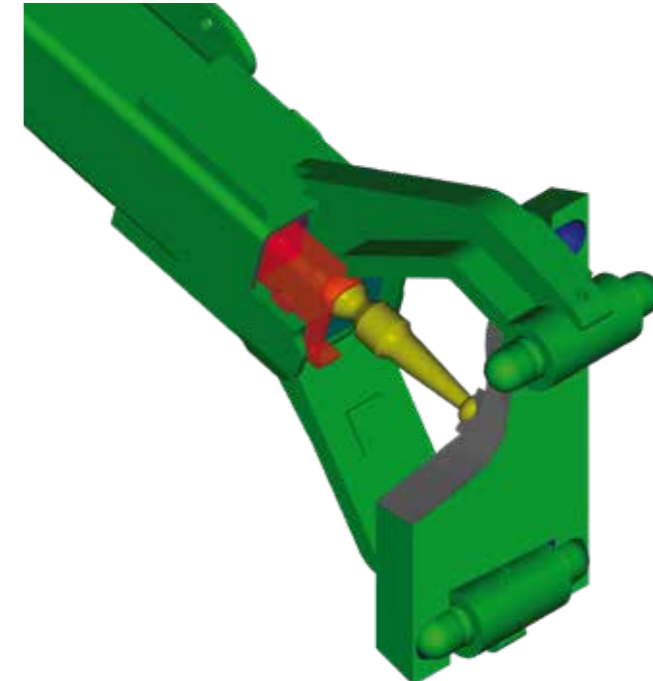

Hydraulic non-stop overload protection

Instead of the pressure spring the hydraulic non-stop overload protection has got an inside mounted hydraulic cylinder, which is pressured via a membrane memory system. The triggering pressure can be changed comfortable from the tractor by the control unit. The adjusted triggering pressure is readable via mounted manometer. A triggering pressure from 50 to 180 bar is possible through this system.

EXTENSIVE PLOUGH BODY PROGRAMME

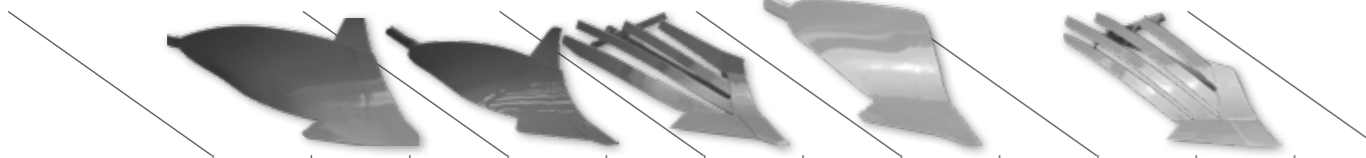

	WS7-38	WS7-42	W7-46	WS794	M4	SKL5	SKL5B	T62	T65	SK6 SKK6	SKT6	SKT65
Field of application	Light soils (sand)	++	+	-	-	++	-	-	-	++	+	-
	Middle soils	++	++	++	+	++	+	+	+	+	++	+
	Heavy soils	+	++	++	+	+	+	++	++	+	+	+
	Very heavy soils (clay)	+	++	++	+	-	+	++	++	-	++	++
	Light, sticky soils (moor)	--	--	--	--	+	++	+	+	++	++	+
	Heavy, sticky soil (clay)	-	-	-	++	--	+	+	+	+	-	+
Requirement	Hillside location	+	+	++	+	+	++	+	-	--	-	--
	Soil crumbling	+	++	++	+	++	++	+	+	+	-	+
	Furrow clearing	+	+	++	+	+	+	++	-	-	+	-
	Low tractive power requirement	++	++	+	+	+	++	+	-	--	+	-
	Soil turning	+	++	++	+	++	+	+	+	-	+	-
Min. working depth (cm)	12	15	15	20	15	15	12	22	25	16	18	20
	25	28	30	35	32	30	30	45	50	30	35	50
Max. working depth (cm)	55	55	58	58	55	55	55	60	60	55	60	60

++ Very well suited + Well suited - Suited -- Less suited
Data listed are intended as reference values only. Due to local soil conditions data may differ.

The right body for every soil – perfection down the last detail

The plough body is one of the core elements of the plough. This is where Regent uses its 90-year-expertise in plough technology. For every REGENT plough body forms are used, which are treated with special developed hardening methods. A portfolio of many different body forms allows to make the right choice for every type of soil, that is how each body form of REGENT overcomes any challenge with bravura.

WS7 working depth from 12 to 28 cm

Full steel sheet and universal body form at the same time. The model range WS7 connects both and is perfect for the use in light up to middle soils. A spacious furrow cleaning, good hillside capability as well as easy pulling characterizes this model range.

W7 working depth from 15 to 30 cm

A more sustained form, similar to WS7 – perfect also for heavy soils and a very good hillside capability.

WS794 working depth from 18 to 32 cm

A long drawn out body shape for light to middle soils. Easy pulling and a good hillside capability characterizes this model range.

M4 working depth from 15 to 32 cm

An universal body for light to heavy soils. This body has got a very good crumbling.

T6 working depth from 22 up to over 50 cm

A model range for hard work. Through its cylindric form these bodies enable depth, but easy pulling ploughing. Working width from 22 up to over 50 cm possible.

SKL working depth from 15 to 30 cm

A slatted body if the soil tends to be sticky. As option also available with a broader furrow cleaning (model "B").

SK working depth from 16 to 30 cm

A slatted body for soils, which tend to be sticky. As option available with a mouldboard tip made of plastic (model "SKK").

SKT working depth from 18 to 50 cm

A slatted body, which enlarges the possibilities of the model range T6. Due to its slatted form it is able to plough even at sticky soil conditions.

Beak share SN

Mounted as standard on your plough (except non-stop models).

The beak share SN has got a well-developed beak share top. High stability, an outstanding lifetime and self sharpening are the qualities of this share.



Beak share S

Mounted as standard on all non-stop plough models. Developed for the use in stony fields. The beak share top, which is not so strong pronounced avoids putting forth stones to the surface.



Share DW-DWS

Chisel opener DW with reversible point DWS.

The universal share with best moving-in reaction.



Share SW-SWS

Share SW with reversible point SWS

Constructed for the daily use. Long lifetime, very good moving-in reaction also for dry soils – these are the strengths of this share.



Share SW-XWS

Share SW with reversible point XWS

Constructed for extreme use. The long drawn XWS share is connected with the trunk of the body, hereby a higher stability of the share is given.

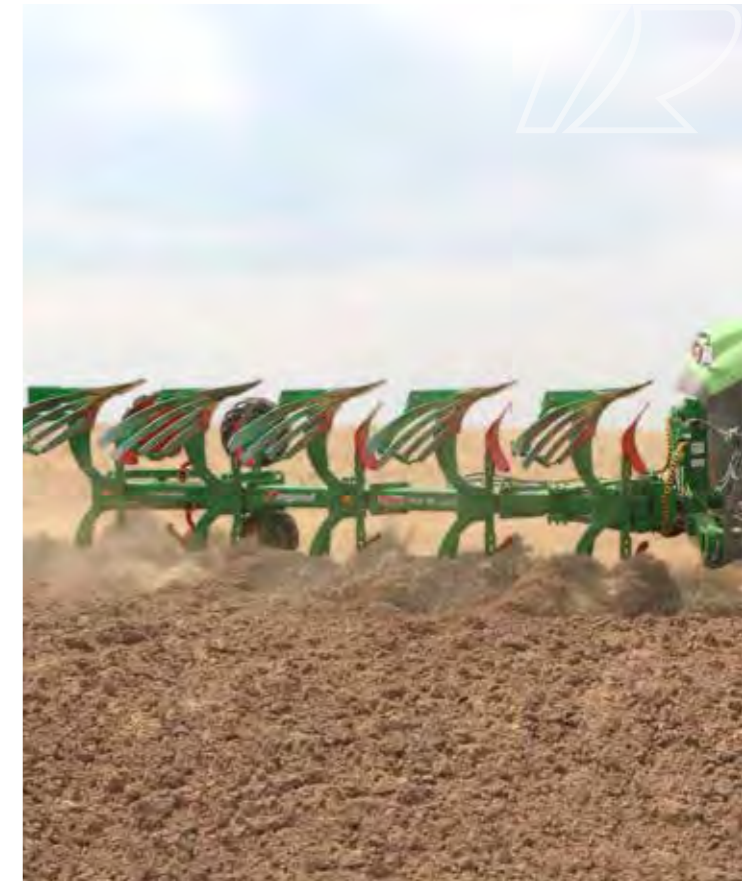

Cutting width adjustment hydraulic

Through the hydraulic cutting width adjustment the spindle C which is placed across the driving direction is replaced by a double acting hydraulic cylinder. This enables the adjustment of the cutting of the first body hydraulically from the tractor.



Special turning control valve

With the special turning control valve you are able to control hydraulically the camber adjustment via the turning cylinder which is available optionally.



Marker boards with lightning

As option all ploughs can be equipped with marker boards and lightning.



TILLAGE TOOLS

Skimmer F

For an optimal use from the grassland ploughing up to maize straw.



Skimmer MSE

For extreme conditions, a lot of crop residues is no problem. Developed specially for maize straw and catch crops.



Skimmer BV 27

Special skimmer for extreme use on the field. Developed for heavy, dry soils with a high ploughing depth.



Wide furrow cutter

The wide furrow cutter cracks the edge of the plough furrow and this makes the use of extreme broad tractor wheels possible.



Knife couler

The knife couler serves as an option for the disc couler. It prevents drifting of the plough on the hillside. Less weight and therefore less lifting power are also advantages of the knife coulers.



Disc couler

The disc couler supports the complete turning of the earth ridges, as well as the working in of crop residues. A clean furrow cleaning is granted through an exact cut.

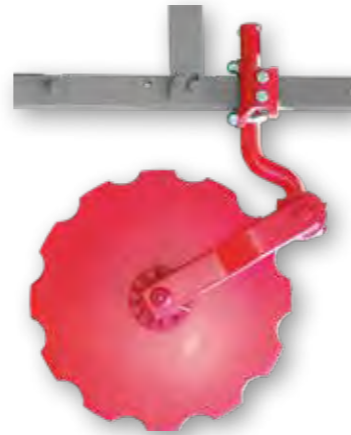

The disc couler is adjustable in all directions and therefore is able to get adapted to every given situation.

- In driving direction by means of a holding rail
- Distance to the plough body by means of an arm
- Cutting depth by means of a ratchet disc or spring pressure (pressured model)

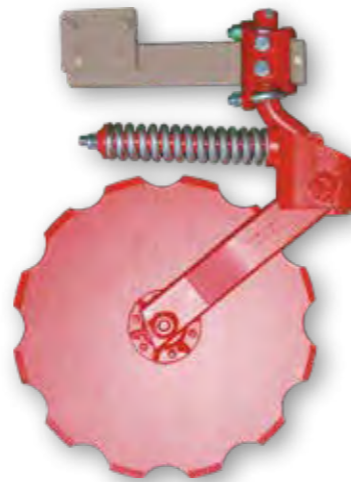

Trashboard

The perfect aid for stony or shallow soils.



Subsoil decompactor-mandrel

Through to its special pointed shape the subsoil decompactor-mandrel achieves a very good loosening effect. Two versions offer the right tool for every use.

- Versions:
- V250 (screwed version)
 - VAS250 (adjustable in height and removable tool-free)



THE RIGHT DEPTH WHEEL FOR EVERY USE

Dual depth wheel

The dual depth wheel is the perfect aid for fenceline ploughing. Due to the near mounting on the plough frame a high ground clearance at turning and inside run of the wheel are possible. Different wheels for every use cover a wide range of applications.

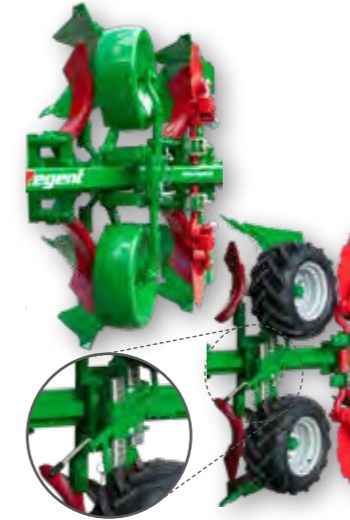

Lever adjustment

The central adjustment of both depth wheels with just one hand

Depth/transport and support wheel

Perfect guidance of the plough in the field and a perfect performance on the street are possible through swivelling of the wheel. All depth/transport and support wheels have a hydraulic locking system HVS as standard, which prevents the wheel against unintentional running on the slope as well as a hydraulic depth adjustment.



Pendulum depth wheel

The pendulum depth wheel enables the use of one depth wheel for both sides of the plough. Via a pendulum mechanism the wheel swivels to the other side of the plough during the turning process. A thorn prevents the model MG against running forward on the slope. The model SG (with hydraulic locking) prevents the wheel against unintentional running on the slope by a mounted hydraulic cylinder and a spring.



Pendulum depth wheel with hydraulic depth adjustment

A double acting hydraulic cylinder enables to adjust the depth steplessly in an easy and comfortable way from the tractor.



	Dual depth wheel Steel tire ø510x185 mm	Dual depth wheel rubber tire ø500x200 mm	Dual depth wheel rubber tire ø580x250 mm	Dual depth wheel rubber tire ø620x220 mm	Pendulum depth wheel MG rubber tire ø620x220 mm	Pendulum depth wheel SG rubber tire ø620x220 mm	Pendulum depth wheel SG rubber tire ø700x260 mm	Pendulum depth wheel SG rubber tire ø700x300 mm	Pendulum depth wheel SG rubber tire ø700x350 mm	Depth/transport and support wheel rubber tire ø700x300 mm	Depth/transport and support wheel rubber tire ø700x350 mm
	70 kg	70 kg	95 kg	100 kg	80 kg	110 kg	110 kg	115 kg	125 kg	150 kg	165 kg
Eurostar 100	✓	✓	✗	✗	✓	✗	✗	✗	✗	✗	✗
Eurostar 120	✓	✓	✓	✓	✓	✓	✗	✗	✗	✗	✗
Eurostar 400	✓	✗	✓	✓	✗	✗	✓	✗	✗	✓	✗
Eurostar 500	✓	✗	✓	✓	✗	✗	✓	✓	✗	✓	✗
Eurostar 600	✓	✗	✓	✓	✗	✗	✓	✓	✓	✓	✓
Eurostar 700	✓	✗	✓	✓	✗	✗	✓	✓	✓	✓	✓
Eurostar 100 n-s	✓	✓	✗	✗	✓	✗	✗	✗	✗	✗	✗
Eurostar 120 n-s	✓	✓	✓	✗	✓	✓	✗	✗	✗	✗	✗
Eurostar 400 n-s	✓	✗	✓	✓	✗	✗	✓	✗	✗	✓	✗
Eurostar 450 n-s	✓	✗	✓	✓	✗	✗	✓	✗	✗	✓	✗
Eurostar 600 n-s	✓	✗	✓	✓	✗	✗	✓	✓	✓	✓	✓
Titan 120	✓	✓	✓	✓	✗	✓	✓	✓	✗	✗	✗
Titan 140	✓	✗	✓	✓	✗	✓	✓	✓	✗	✓	✗
Titan 160	✓	✗	✓	✓	✗	✗	✓	✓	✗	✓	✗
Titan 180	✓	✗	✓	✓	✗	✗	✓	✓	✓	✓	✓
Titan 200	✓	✗	✓	✓	✗	✗	✓	✓	✓	✓	✓
Titan 140 n-s	✓	✗	✓	✓	✗	✗	✓	✓	✗	✓	✗
Titan 160 n-s	✓	✗	✓	✓	✗	✗	✓	✓	✗	✓	✗
Titan 200 n-s	✓	✗	✓	✓	✗	✗	✓	✓	✓	✓	✓

THE RIGHT PLOUGH FOR EACH PERFORMANCE.

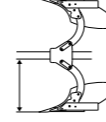
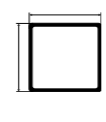

		Shares / weight kg								Frame dimension mm	Spacing of bodies cm	Working width cm	Framework height cm	kW / HP																			
		2	3	4	5	6	7	8	9					59	74	88	103	118	132	147	162	177	191	206	221	257	294	331	450				
		mech. furrow width adjustment																															
Eurostar		100	570	750						100x120	97	32 37 42 47	73	77																E 100 2-3			
		120 S		790	1000					100x120	85	28 33 37 41	77	80																E 120 S 3-4			
		120 M	650	810	1030					100x120	100	33 38 43 49		80																E 120 M 2-4			
		400		960	1230	1440				120x120	100	32 35 40 45 50		82																E 400 3-5			
		500			1310	1560				140x140	103	38 42 45 48 52		82																E 500 4-5			
		600			1515	1780	2170			180x140/120	100	37 41 45 48 52	83	86																E 600 4-6			
		700				1990	2270			180x140	103	39 43 47 51 53	83	86																E 700 5-6			
	non-stop		100 n-s	740							100x120	97	36 40 45 50	73	77															E 100 NS 2			
			120 S n-s		1110	1380					100x120	85	31 35 39 44 47	73	77															E 120 S NS 3-4			
			120 M n-s	780	1140	1420					100x120	100	37 42 46 52	77	80															E 120 M NS 2-4			
			400 K n-s			1590	1918				120x120	89	34 37 40 43 46 49	78																E 400 K NS 4-5			
			400 n-s			1608					120x120	100	38 42 45 48 52	78																E 400 NS 4			
			450 n-s			1640	1980				120x140	100	38 42 45 48 52	78																E 450 NS 4-5			
		600 n-s			1860	2280	2795			150x150	100	37 41 45 49 52	78	82															E 600 NS 4-6				
Titan		120 M			1140					100x120	100	29 - 52		80															T 120 4				
		140 C			1280	1530				140x120	90	31 - 49		82															T 140 C 4-5				
		140 M		1020	1300	1560				140x120	100	31 - 51		82															T 140 M 3-5				
		140 SL		960						140x120	104	31 - 52		82															T 140 SL 3				
		140 L		1080	1320	1580				140x120	104	31 - 52		82															T 140 CT 3-5				
		160 M			1340	1760				160x120	100	33 - 52		82															T 160 M 4-5				
		160 L		1130	1370	1770				160x120	106	34 - 54		82															T 160 TT 3-5				
		180 M			1650	1900	2240			180x140	100	33 - 58	79	83	86														T 180 M 4-6				
		180 L			1670	1950	2380			180x140	106	33 - 60	79	83	86														T 180 L 4-6				
		200 S			1700	2000	2430			200x150	100	33 - 53	83	86	92														T 200 S 4-6				
		200 TL		1350	1810					200x150	117	36 - 58		86															T 200 TL 3-4				
	non-stop		140 C n-s		1300	1640					140x120	90	30 - 47	77	80															T 140 C NS 3-4			
			140 M n-s		1320	1700					140x120	100	32 - 51	77	80															T 140 M NS 3-4			
			140 L n-s		1330	1700					140x120	104	32 - 51	77	80															T 140 CT NS 3-4			
		160 M n-s			1800	2170				160x120	100	33 - 52	77	80															T 160 T NS 4-5				
		160 L n-s		1395	1850					160x120	106	34 - 54	82																T 160 TT NS 3-4				
		200 S n-s			1950	2350	2750			200x150	100	34 - 52	80	84															T 200 S NS 4-6				
Taurus		E 180				3230	3610	3950		180x140	100	37 41 45 48 52	83															Taurus E 180 6-8					
		180 M				3300	3710	4080		180x140	100	34 - 53	83															Taurus 180 M 6-8					
		200 S				3400	3730	4100	4500	200x150	100	34 - 53	83	86														Taurus 200 S 6-9					
		200 TL				3300	3600	4000		200x150	117	36 - 55		86														Taurus 200 TL 5-7					
	n-s	200 S n-s				3950	4350	4750	5200	200x150	100	33 - 50	80	84														Taurus 200 S NS 6-9					

Weight approximately - depending on plough body and spacing of bodies without additional equipment.

TYPES AND POWER REQUIREMENT TAB

ONLY WITH THE RIGHT PLOUGH
PLOUGHING IS A PLEASURE



Regent Pflugfabrik GmbH
Bahnhofstr. 105
4800 Attnang-Puchheim
Austria



Tel. +43 7674 62661
Fax. +43 7674 62207
info@regent.at
www.regent.at

